

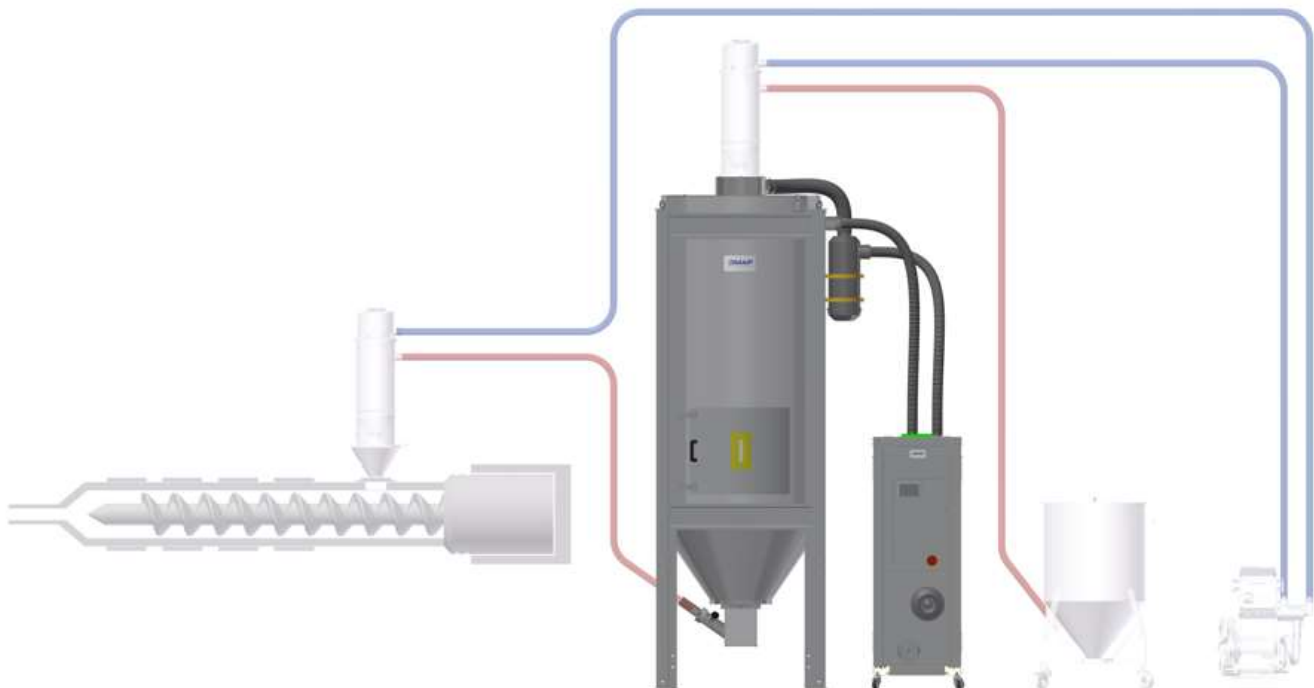

WDS.E 150 series

NEW OMAP
never stop innovating





WDS.E		WDS150.E/HT-300	WDS150.E/HT-400
Portata massima <i>Maximum flow</i>	m ³ /h	150	150
Volume tramoggia <i>Hopper capacity</i>	dm ³	300	400
Carrello <i>Trolley</i>	-	Optional	Optional
Tensione & frequenza <i>Voltage & frequency</i>	-	400V/50Hz/3PH+N	400V/50Hz/3PH+N
Potenza <i>Power</i>	kW	8	8
Campo di temperature MT <i>MT temperature range</i>	°C	70 - 150	70 - 150
Campo di temperature HT <i>HT temperature range</i>	°C	60 - 170	60 - 170
Riscaldamento processo <i>Process heating</i>	kW	4.5	4.5
Tubi di collegamento <i>Connecting pipes</i>	ø mm	64	64
Temperatura dell'acqua in ingresso <i>Inlet water temperature</i>	°C	18	18

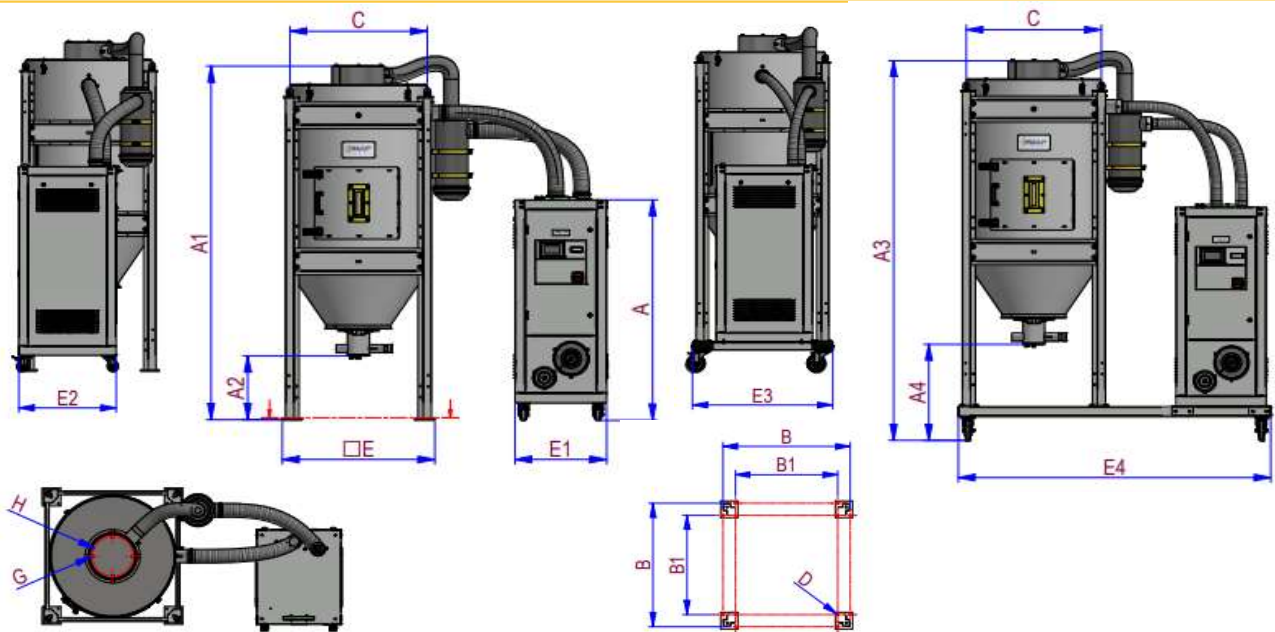

WDS.E		WDS150.E/HT-300	WDS150.E/HT-400	WDS150.E/HT-300 +carrello	WDS150.E/HT-400 +carrello
A	mm	1375	1375	/	/
A1	mm	2210	2510	/	/
A2	mm	380	380	/	/
A3	mm	/	/	2425	2735
A4	mm	/	/	590	590
B	mm	880	880	/	/
B1	mm	708	708	/	/
C	mm	824	824	824	824
D (ø)	mm	12	12	/	/
□ E	mm	914 x 914	914 x 914	/	/
E1	mm	550	550	/	/
E2	mm	635	635	/	/
E3	mm	/	/	926	926
E4	mm	/	/	1906	1906
G	mm	M6	M6	M6	M6
H (ø)	mm	265	265	265	265