

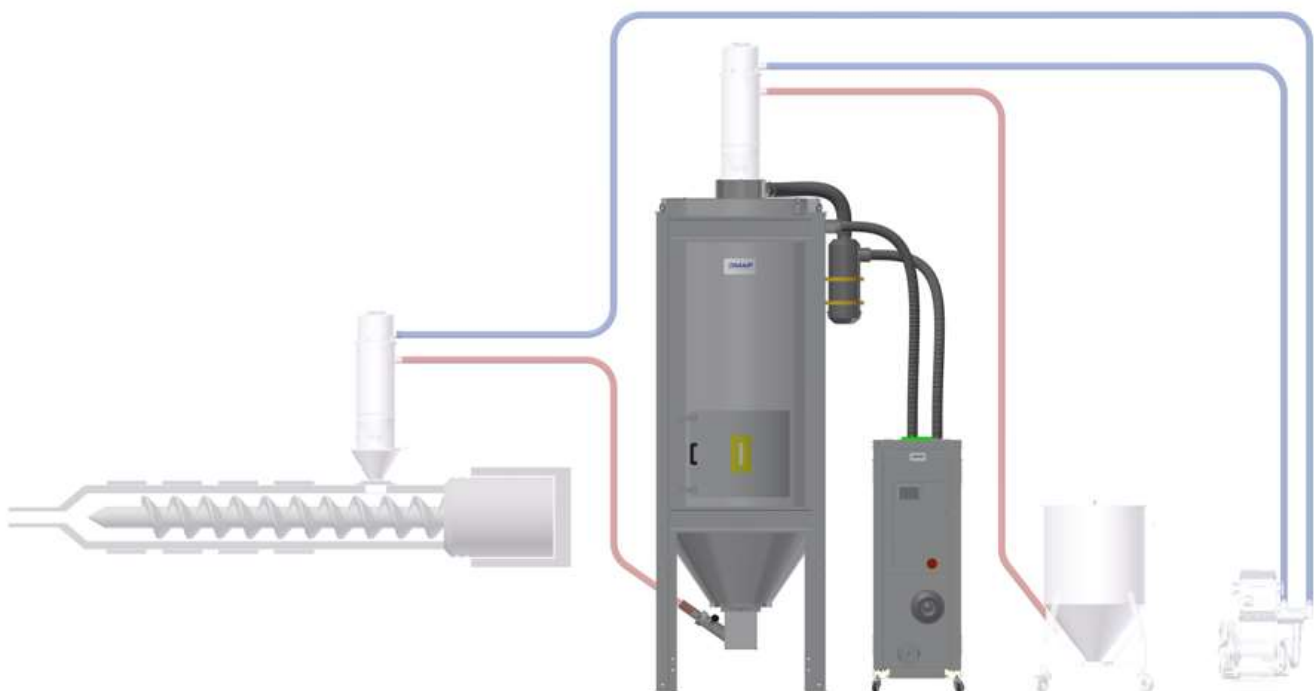

WDS.E 350 series

NEW OMAP
never stop innovating





WDS.E		WDS350.E-800	WDS350.E-1000	WDS350.E-1500
Portata massima <i>Maximum flow</i>	m ³ /h	350	350	350
Volume tramoggia <i>Hopper capacity</i>	dm ³	800	1000	1500
Carrello <i>Trolley</i>	-	No	No	No
Tensione & frequenza <i>Voltage & frequency</i>	-	400V/50Hz/3PH+N	400V/50Hz/3PH+N	400V/50Hz/3PH+N
Potenza <i>Power</i>	kW	13.5	13.5	13.5
Campo di temperature MT <i>MT temperature range</i>	°C	70 - 150	70 - 150	70 - 150
Campo di temperature HT <i>HT temperature range</i>	°C	60 - 170	60 - 170	60 - 170
Riscaldamento processo <i>Process heating</i>	kW	7.5	7.5	7.5
Tubi di collegamento <i>Connecting pipes</i>	ø mm	90	90	90
Temperatura dell'acqua in ingresso <i>Inlet water temperature</i>	°C	18	18	18

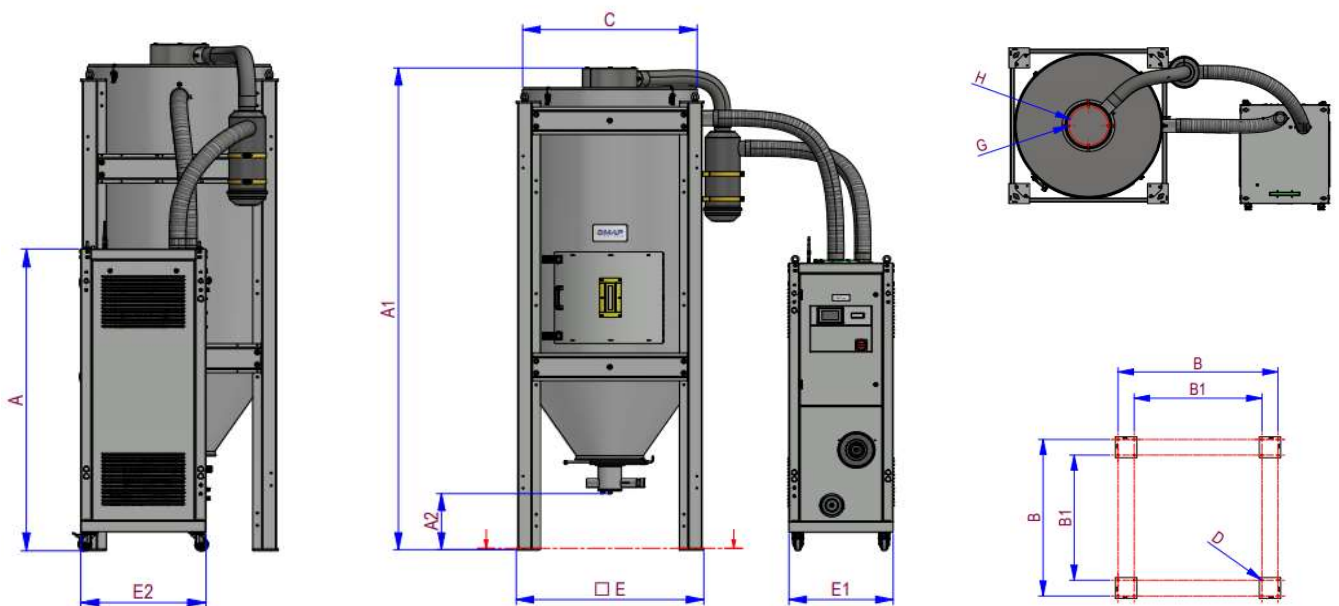

WDS.E		WDS350.E-800	WDS350.E-1000	WDS350.E-1500
A	mm	1700	1700	1700
A1	mm	2860	3215	3640
B	mm	1045 x 1045	1045 x 1045	1255 x 1255
B1	mm	835 x 835	835 x 835	995 x 995
C (ø)	mm	1004	1004	1180
D (ø)	mm	12	12	12
E	mm	1080 x 1080	1080 x 1080	1295 x 1295
E1	mm	600	600	600
E2	mm	685	685	685
G	mm	M6	M6	M6
H (ø)	mm	265	265	265